Cranbourne Terminal Station Electricity Supply

RIT-T Stage 1: Project Specification
Consultation Report (PSCR)



ISSUE/AMENDMENT STATUS

Issue Number	Date	Description	Author	Approved by
1	17/06/2020	Issue 1	Danielle Johnstone (AST) Jason Pollock (AST) Christopher Roberts (UE)	Tom Langstaff (AST) Hedy Dalvand (UE)

Disclaimer

This document may or may not contain all available information on the subject matter this document purports to address. The information contained in this document is subject to review and may be amended any time.

To the maximum extent permitted by law, AusNet Services and United Energy makes no representation or warranty (express or implied) as to the accuracy, reliability, or completeness of the information contained in this document, or its suitability for any intended purpose. AusNet Services and United Energy (which, for the purposes of this disclaimer, includes all of its related bodies corporate, its officers, employees, contractors, agents and consultants, and those of its related bodies corporate) shall have no liability for any loss or damage (be it direct or indirect, including liability by reason of negligence or negligent misstatement) for any statements, opinions, information or matter (expressed or implied) arising out of, contained in, or derived from, or for any omissions from, the information in this document.

Contact

This document is the responsibility of AusNet Services and United Energy.

Please contact the indicated owner of the document with any inquiries.

AusNet Services
Level 31, 2 Southbank Boulevard
Melbourne Victoria 3006

United Energy
PO Box 449
Mount Waverley
VIC 3149

Table of Contents

1	Executive summary	4
1.1	Identified need	4
1.2	Options	4
1.3	Submissions	5
1.4	Next steps.....	5
2	Introduction	6
3	Identified Need	7
3.1	Background	7
3.2	Description of the identified need	7
3.3	Assumptions used in identifying the identified need	9
4	Technical characteristics of the identified need.....	15
4.1	Data requirements from non-network service providers	16
5	Potential credible options to address the identified need.....	18
5.1	Option 1 – Do nothing	18
5.2	Option 2 – Contract network support services	18
5.3	Option 3 – Install fourth 220/66 kV transformer at CBTS	18
5.4	Option 4 – Install two 50 MVAR 66 kV capacitor banks	19
5.5	Option 5 – Establish two new 22 kV feeders to offload CBTS	19
5.6	Option 6 – Establish a new 220/66kV terminal station.....	19
6	Submissions and next steps	20
6.1	Request for submissions	20
6.2	Next steps.....	20

1 Executive summary

AusNet Services and United Energy are regulated Victorian Distribution Network Service Providers (DNSPs) that supply electrical distribution services to more than 745,000 and 685,000 customers, respectively. AusNet Services' electricity distribution network covers eastern rural Victoria and the fringe of the northern and eastern Melbourne metropolitan area, while United Energy's electricity distribution network covers the east and south east Melbourne suburbs and the Mornington Peninsula.

As expected by our customers and required by the various regulatory instruments that we operate under, AusNet Services and United Energy aim to maintain service levels at the lowest possible cost to our customers. To achieve this, we assess options and develop plans that aim to maximise the present value of economic benefit to all those who produce, consume and transport electricity in the National Electricity Market (NEM). Where relevant, this includes preparation of and consultation on regulatory investment tests. In Victoria, the DNSPs have responsibility for planning and directing augmentation of the transmission connection assets that connect their distribution systems to the Victorian Shared Transmission System. This project relates to the transmission connection assets at Cranbourne Terminal Station (CBTS) and as such is subject to a regulatory investment test for transmission (RIT-T).

CBTS provides supply to parts of the AusNet Services and United Energy electricity distribution networks. This project specification consultation report (PSCR) is stage one of the Cranbourne Terminal Station Electricity Supply RIT-T consultation process and has been jointly prepared by AusNet Services and United Energy in accordance with the requirements of Clause 5.16 of the National Electricity Rules (NER). This notice contains information to enable prospective non-network providers to propose alternative options, such as demand side response solutions or embedded generation.

1.1 Identified need

CBTS provides electricity supply to approximately 168,000 customers, which are primarily residential with some light industrial and commercial customers as well. The geographic area supplied by CBTS spans from Narre Warren in the north to Clyde in the south, and from Pakenham in the east to Carrum and Frankston in the west. Electricity demand in the CBTS geographic area has been amongst the fastest growing regions in Victoria and the station has reached capacity. The summer peak actual demand increased by 146 MVA between 2007/08 and 2018/19, which corresponds to an average annual growth rate of 3.5%.

The identified need is the need to maintain electricity supply reliability for customers in the CBTS supply area. Due to the strong demand growth in the area, the level of expected unserved energy (EUSE) is forecast to grow, significantly deteriorating the level of customer reliability due to insufficient supply capacity from CBTS. Meeting this identified need will result in an increase in the producer and consumer surplus (a net economic benefit to all those who produce, consume and transport electricity in the NEM) by reducing the cost of expected unserved energy by more than the proposed preferred solution's implementation and ongoing operating and maintenance costs.

The need for this investment has been foreshadowed in the Transmission Connection Planning Reports (TCPR), published jointly by all Victorian Distribution Businesses.

1.2 Options

The potentially credible options considered to address the identified need include:

- Option 1 - Do Nothing;
- Option 2 - Non-network solution;
- Option 3 - Install fourth 220/66 kV transformer at CBTS;
- Option 4 - Install two 50 MVAR 66 kV capacitor banks;
- Option 5 - Establish two new feeders to offload CBTS;
- Option 6 - Establish a new 220/66 kV terminal station.

At this stage, Option 3 has been identified as the preferred network option that maximises the net market benefits.

Cranbourne Terminal Station Electricity Supply RIT-T

1.3 Submissions

AusNet Services and United Energy welcome written submissions or enquires on the topics and the credible options presented in this PSCR and invite proposals from proponents of potential non-network options.

Submissions should be emailed on or before 25 September 2020. Submissions and enquires should be directed to the following addresses:

- Jason.Pollock@AusNetServices.com.au
- Christopher.Roberts@ue.com.au

Submissions will be published on the Australian Energy Market Operator (AEMO), AusNet Services and United Energy websites. If you do not wish for your submission to be published please clearly stipulate this at the time of lodging your submission.

1.4 Next steps

Following conclusion of the PSCR consultation period, AusNet Services and United Energy will, having regard to any submissions received on the PSCR, prepare and publish a project assessment draft report (PADR). AusNet Services and United Energy intend on publishing the PADR in Q4 2020.

2 Introduction

The regulatory investment test for transmission (RIT-T) is an economic cost-benefit test used to assess and rank potential investments capable of meeting the identified need. The purpose of the RIT-T is to identify the credible option that maximises the present value of net economic benefit to all those who produce, consume and transport electricity in the National Electricity Market (the preferred option).

This project specific consultation report (PSCR) is the first stage of the Cranbourne Terminal Station (CBTS) Electricity Supply RIT-T consultation process and has been jointly prepared by AusNet Services and United Energy in accordance with the requirements of Clause 5.16 of the National Electricity Rules (NER).

This report:

- Describes the identified need that AusNet Services and United Energy is seeking to address, which is in relation to the Cranbourne Terminal Station limitations.
- Outlines the proposed assessment methodology and assumptions made in identifying the need.
- Describes the options that AusNet Services and United Energy considers could potentially address the identified need.
- Outlines the technical characteristics that a non-network option would be required to deliver in order to meet the identified need.
- Invites registered participants, AEMO, interested parties, non-network providers and persons on AusNet Services' and United Energy's demand side engagement registers to make a submission on this PSCR.

3 Identified Need

3.1 Background

Cranbourne Terminal Station (CBTS) was originally commissioned, with two 150 MVA 220/66 kV transformers, in 2005 to reinforce the security of supply and off-load East Rowville Terminal Station (ERTS). In 2009, a third 150 MVA 220/66 kV transformer was commissioned to supply the rapidly growing electricity demand in the area. CBTS provides electricity supply to approximately 168,000 customers, which are primarily residential with some light industrial and commercial customers as well. The geographic area supplied by CBTS spans from Narre Warren in the north to Clyde in the south, and from Pakenham in the east to Carrum and Frankston in the west, as shown in Figure 1. CBTS supplies the AusNet Services and United Energy distribution networks with a split of 62% and 38% respectively, based on average annual energy consumption.

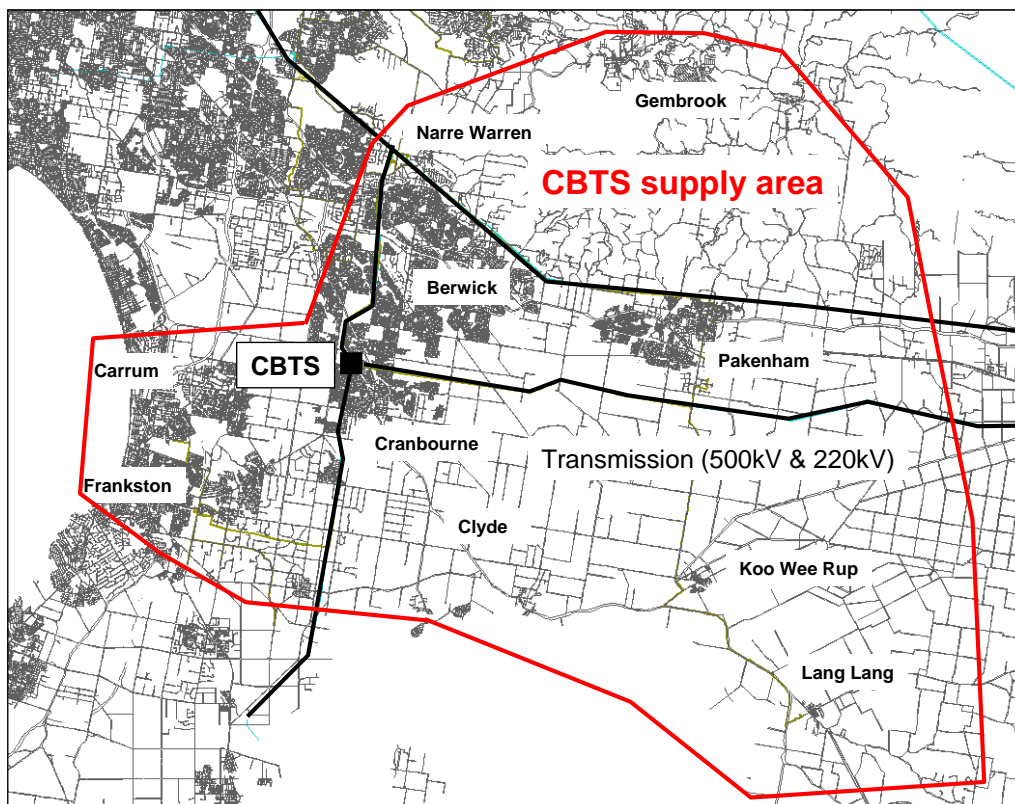

Figure 1 - CBTS supply area map

CBTS is a summer peaking station. Electricity demand in the CBTS geographic area has been amongst the fastest growing regions in Victoria. The summer peak actual demand increased by 146 MVA between 2007/08 and 2018/19, which corresponds to an average annual growth rate of 3.5%. The peak demand for summer 2019/20 continued to grow reaching 486 MVA, which is the highest recorded peak demand at CBTS. In addition, it is estimated that the demand would have exceeded 500 MVA if a fault and load transfer had not occurred around the time of peak demand. At maximum demand, CBTS has a power factor of 0.97.

3.2 Description of the identified need

The identified need is the need to maintain electricity supply reliability for customers in the CBTS supply area. Due to the strong demand growth in the area, supply reliability will significantly deteriorate resulting in increased levels of expected unserved energy (EUSE) from CBTS. Meeting this identified need will result in an increase in the producer and consumer surplus (a net economic benefit to all those who produce, consume and transport electricity in the NEM) by reducing the cost of expected unserved energy by more than the proposed preferred solution's implementation and ongoing operating and maintenance costs.

Cranbourne Terminal Station Electricity Supply RIT-T

There is insufficient capacity to supply the growing demand at CBTS from 2021 under system normal (“N”) operating conditions for a 10% probability of exceedance (PoE) maximum demand. The station N rating is also reached under a 50% PoE forecast from summer 2028/29. In addition, the historical and forecast maximum demand under a transformer outage scenario (“N-1”) has exceeded the rating since 2011/12, with significant levels of load at risk during peak loading periods. The network limitations and the detail underpinning the identified need is discussed further in the following sections.

3.2.1 Thermal capacity limitations

The summer cyclic “N” rating of CBTS is 538 MVA at 35°C ambient temperature and 525 MVA at 40°C ambient temperature. The summer cyclic “N-1” rating of CBTS is 359 MVA at 35°C ambient temperature and 350 MVA at 40°C temperature.

If the N rating is exceeded, or one of the 220/66 kV transformers at CBTS is taken out of service during peak loading times when the N-1 station rating is exceeded, the Overload Shedding Scheme for Connection Assets (OSSCA)¹, which is operated by AusNet Services’ Transmission Operations Centre, will act swiftly to reduce load in blocks to within ratings of available plant. If OSSCA operates it would automatically shed up to 180 MVA of load, affecting up to 70,000 customers. Any load reductions that are in excess of the minimum amount required to limit load to the rated capability of the station would be restored at zone substation feeder level in accordance with United Energy’s and AusNet Services’ operational procedures.

An assessment of the probability weighed thermal capacity driven supply risks are summarised in Table 1, for system normal conditions, and Table 2, for network outage conditions. Note, pre-contingent actions are required to manage the demand under N conditions whenever demand exceeds the installed transformer capacity, and the expected unserved energy is therefore not weighted by the probability of a transformer outage when monetising the supply risk. The expected unserved energy is estimated using a 30:70 weighting of the 10% PoE and 50% PoE maximum demand forecasts to account for year on year weather variability. CBTS has an estimated 70 MVA of (N-1) load transfer available in 2020, the impact of which has been included in this assessment.

Table 1 – Forecast system normal thermal limitation supply risk

Year	N Thermal Limitations					
	10% PoE Summer		50% PoE Summer		Risk - Probability Weighted	
	Load at Risk / Network Support Requirement (MVA)	Hours at Risk (Hours)	Load at Risk / Network Support Requirement (MVA)	Hours at Risk (Hours)	Expected Unserved Energy (MWh)	Cost of Expected Unserved Energy (\$k)
2020-21	13.2	7	-	-	12.4	432
2021-22	19.8	9	-	-	28.3	986
2022-23	28.2	12	-	-	54.8	1,907
2023-24	35.4	15	-	-	83.3	2,897
2024-25	47.1	20	-	-	142.6	4,959
2025-26	53.1	22	-	-	178.8	6,218
2026-27	61.9	25	-	-	237.8	8,270
2027-28	70.0	27	-	-	296.9	10,323
2028-29	81.7	29	8.0	1	392.0	13,633

¹ OSSCA is designed to protect connection transformers against transformer damage caused by overloads. Damaged transformers can take months to repair or replace, which can result in prolonged, long term risks to the reliability of customer supply.

Cranbourne Terminal Station Electricity Supply RIT-T

Table 2 Forecast post-contingent thermal limitation supply risk

Year	N-1 Thermal Limitation (Post-contingent support)					
	10% PoE Summer		50% PoE Summer		Risk - Probability Weighted	
	Load at Risk / Network Support Requirement (MVA)	Hours at Risk (Hours)	Load at Risk / Network Support Requirement (MVA)	Hours at Risk (Hours)	Expected Unserved Energy (MWh)	Cost of Expected Unserved Energy (\$k)
2020-21	118.2	58	53.1	15	7.4	259
2021-22	124.8	62	59.6	19	8.6	298
2022-23	133.2	67	68.0	25	10.2	356
2023-24	140.4	71	75.2	30	11.8	412
2024-25	152.1	79	82.2	34	14.2	493
2025-26	158.1	85	88.6	39	15.9	552
2026-27	166.9	94	95.2	44	18.2	632
2027-28	175.0	101	104.5	52	21.1	735
2028-29	186.7	112	117.0	62	25.8	897

3.3 Assumptions used in identifying the identified need

In planning its networks, AusNet Services and United Energy apply a probabilistic planning approach that balances service level risk with the cost of potential risk mitigation options to identify the credible option that maximises the present value of net economic benefit to all those who produce, consume and transport electricity in the National Electricity Market (the preferred option).

The probabilistic planning approach estimates the service level risk of identified network limitations by combining:

- The impact (consequence) of network limitations under various conditions; and
- The likelihood of those limits being reached, considering the combined probabilities of relevant demand, generation and network availability forecasts eventuating.

Service level risk is monetised as the product of:

- Expected unserved energy (EUSE) driven by the identified limitations, in megawatt hours (MWh) per annum; and
- The value of customer reliability (VCR), in \$/MWh.

The credible option that maximises the present value of net economic benefit is identified by:

- Combining the service level risk of each credible option and that option's implementation cost; and
- Identifying the credible option with the lowest present value of total service level risk (including implementation and ongoing operating the maintenance costs).

Application of the probabilistic planning approach often leads to the deferral of action that would otherwise proceed under a deterministic planning standard. Under a probabilistic network planning approach, conditions often exist where some of the load cannot be supplied under rare but possible conditions, such as at peak demand or with a network element out of service. The key assumptions used in applying the probabilistic planning approach include:

- Demand forecasts;
- Load profile characteristics;
- Generation profile characteristics;
- Network characteristics and ratings;
- Network reliability information;
- Value of customer reliability; and
- Discount rate.

Cranbourne Terminal Station Electricity Supply RIT-T

3.3.1 Demand forecasts

The summer peak actual demand increased by 146 MVA between 2007/08 and 2018/19, which corresponds to an average annual growth rate of 3.5%. The peak demand for summer 2019/20 continued to grow reaching 486 MVA, which is the highest recorded peak demand at CBTS. In addition, it is expected the demand would have exceeded 500 MVA if a fault and load transfer had not occurred around the time of peak demand.

Based on present forecasts, this high growth is expected to continue at an average annual compound growth rate of 1.7% under 50% PoE weather conditions. The demand growth in the CBTS supply area is primarily due to the following:

- Staged development of residential estates and other residential subdivisions;
- Commercial developments, such as shopping centres, childcare centres, schools, medical centres and retail hubs, associated with new large residential developments; and
- Development of light industrial areas.

The present demand forecasts were prepared in late 2019 and do not include the impact of the COVID-19 pandemic. AusNet Services and United Energy believe there remains a strong need for increased supply capacity to meet the CBTS demand but will, as part of the Stage 2 RIT-T process, undertake a full review of the demand forecasts and confirm or adjust the timing of any proposed investment.

Table 3 shows the summer and winter maximum demand forecast for CBTS over the next ten-year period, under both 10% and 50% PoE conditions.

Table 3 - CBTS forecast maximum demand (MVA)

Station: CBTS 66 kV	2021	2022	2023	2024	2025	2026	2027	2028	2029
50% PoE Summer Maximum Demand	482.1	488.6	497.0	504.2	511.2	517.6	524.2	533.5	546.0
50% PoE Winter Maximum Demand	364.7	371.5	378.8	387.3	395.7	402.4	409.9	419.3	427.9
10% PoE Summer Maximum Demand	538.2	544.8	553.2	560.4	572.1	578.1	586.9	595.0	606.7
10% PoE Winter Maximum Demand	377.4	383.4	390.2	398.8	407.6	416.1	423.9	433.4	442.1

Cranbourne Terminal Station Electricity Supply RIT-T

Figure 2 shows the historical and forecast summer maximum demand of CBTS, as well as the “N” rating and “N-1” rating at both 35°C and 40°C ambient temperatures.

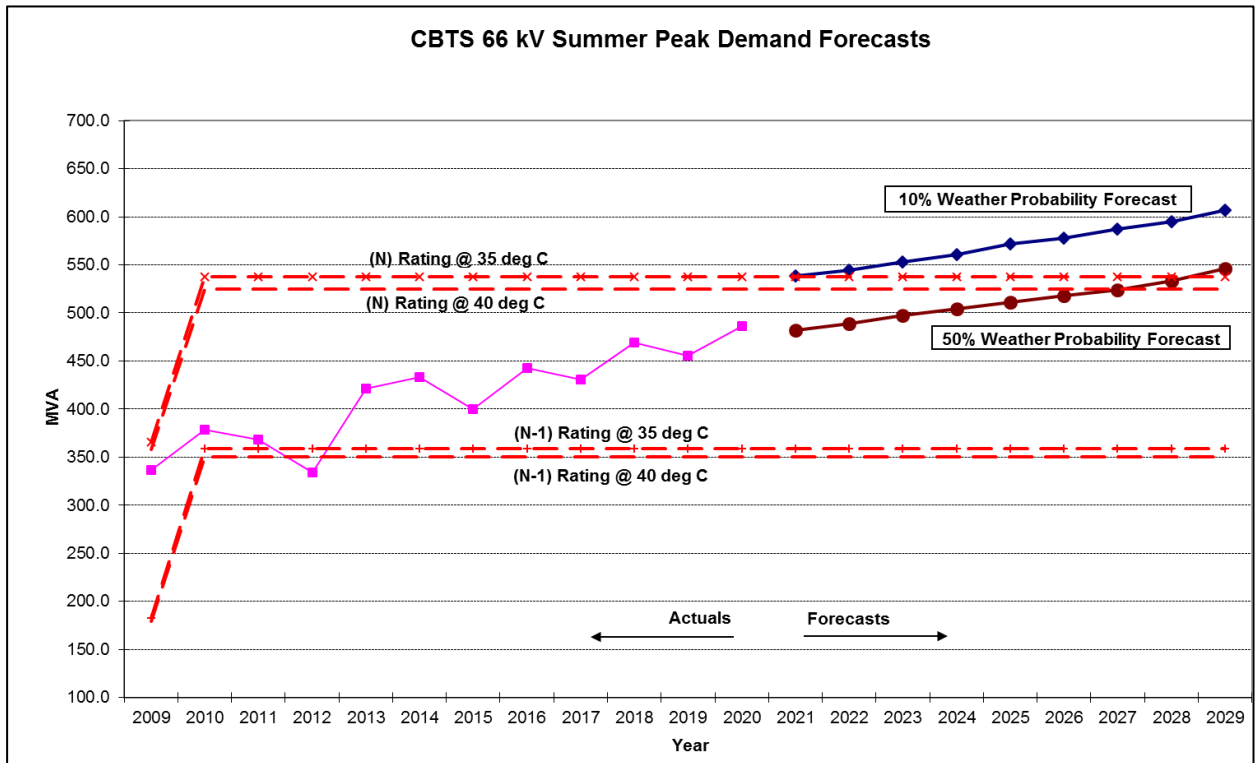

Figure 2 - CBTS historical and forecast summer maximum demand

This figure indicates that under 10% PoE summer maximum demand conditions, the station is forecasted to be above its “N” rating in all forecasted years. Under 50% PoE summer maximum demand conditions, the station is forecasted to be above its “N” rating from 2028/29. If CBTS does exceed its “N” rating, load shedding or emergency load transfers will be required to maintain allowable operating conditions.

Figure 3 presents the historical and forecasted winter maximum demand at CBTS.

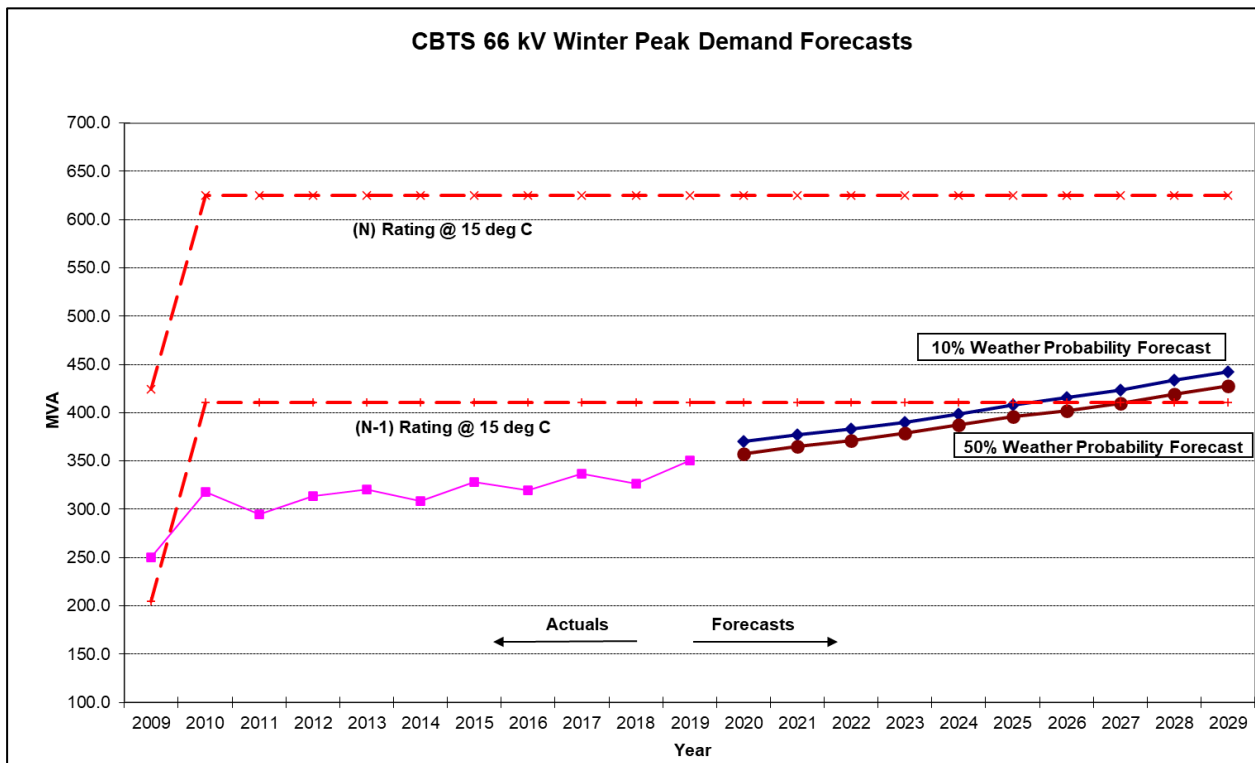

Figure 3 – CBTS Historical and Forecast Winter Maximum Demand

Cranbourne Terminal Station Electricity Supply RIT-T

With much higher ratings, due to lower ambient temperatures, in winter the historical winter maximum demands are below the “N-1” rating for the station. However, demand is forecast to be exceeded the winter rating in 2026 under 10% PoE winter conditions and by 2028 under 50% PoE winter conditions.

3.3.2 Load profile characteristics

Figure 4 shows the CBTS half-hourly demand on the 2019/20 maximum demand day, along with the 2019/20 summer average demand profile. This demonstrates the size, duration and time of day that the peak demand period occurs.

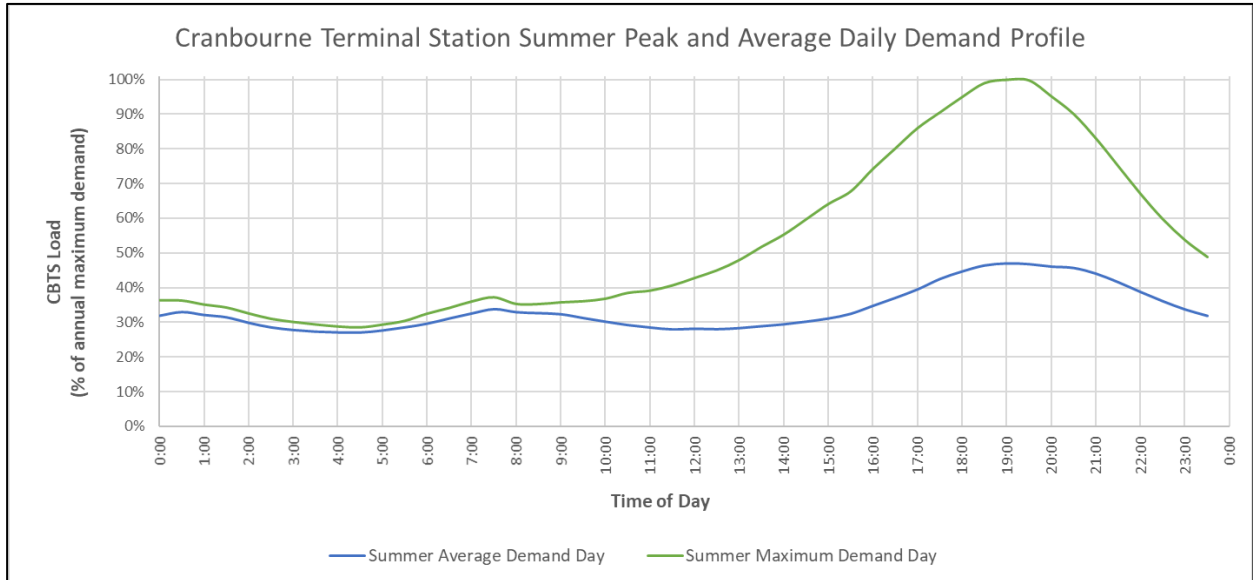

Figure 4 – 2019-20 Cranbourne Terminal Station Summer Peak and Average Daily Demand Profile

Figure 5 shows the CBTS demand duration curves for the past six years. The curves demonstrate the peakiness of the CBTS demand, which is largely driven by temperature sensitive residential demand.

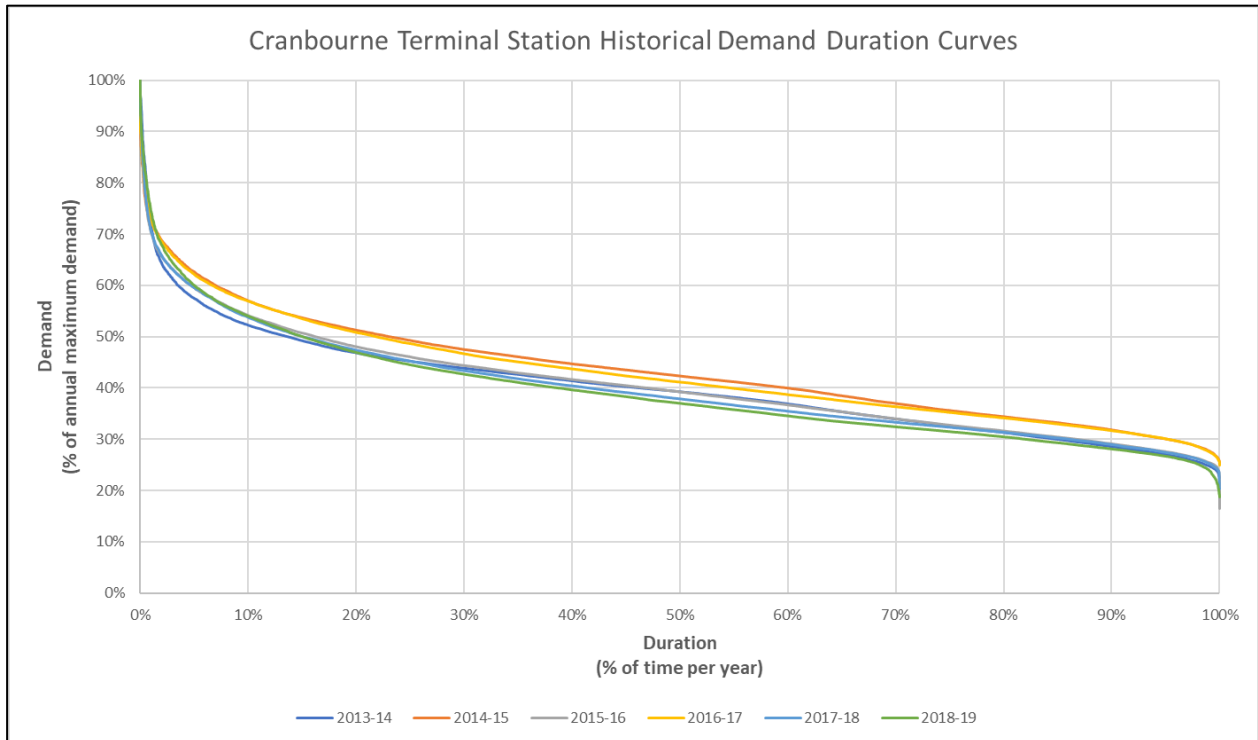

Figure 5 – Cranbourne Terminal Station Historical Demand Duration Curves

Cranbourne Terminal Station Electricity Supply RIT-T

3.3.3 Network characteristics and ratings

CBTS has nine 66 kV sub-transmission line exits supplying eight AusNet Services zone substations, Cranbourne (CRE), Lysterfield (LYD), Narre Warren (NRN), Pakenham (PHM), Officer (OFR), Berwick North (BWN), Lang Lang (LLG) and Clyde North (CLN), and three United Energy zone substations, Carrum (CRM), Langwarrin (LWN) and Frankston (FTN) in a loop via Frankston Terminal Station (FTS). A simplified single line diagram of CBTS is provided in Figure 6.

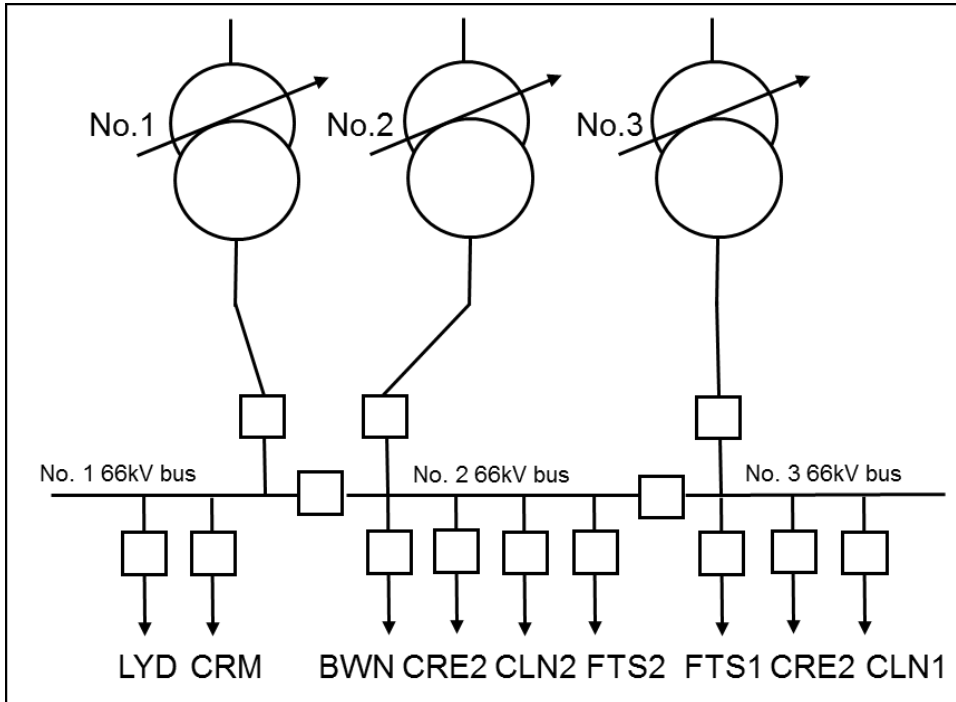

Figure 6 - CBTS single line diagram

Table 4 details the station’s ratings, derived from the currently installed transformer ratings. Included is both the “N” and “N-1” ratings, as well as the ratings under different ambient temperature conditions. Further details on the downstream assets can be provided upon request.

Table 4 – CBTS currently installed transformer ratings

	N Rating (MVA)	N-1 Rating (MVA)
Summer Cyclic Rating (35°C)	538	359
Summer Cyclic Rating (40°C)	525	350
Winter Cyclic Rating (15°C)	625	411

Cranbourne Terminal Station Electricity Supply RIT-T

3.3.4 Network reliability information

Estimates of the expected unserved energy at each terminal station is based on the expected reliability performance of the supplying transformers. The base reliability data adopted for this report is summarised in Table 5, and is as presented in the 2019 Transmission Connection Planning Report.

Table 5 – Terminal station asset reliability data

Major plant item: Terminal station transformer		Interpretation
Major outage rate for transformer	1.0% per annum	A major outage is expected to occur once per 100 transformer-years. Therefore, in a population of 100 terminal station transformers, you would expect one major failure of any one transformer per year.
Weighted average of major outage duration	2.6 months	On average, 2.6 months is required to return the transformer to service, during which time the transformer is not available for service.
Expected transformer unavailability due to a major outage per transformer-year	$0.01 \times 2.6/12 = 0.217\%$ approximately	On average, each transformer would be expected to be unavailable due to major outages for 0.217% of the time, or 19 hours per year.

3.3.5 Value of customer reliability

The cost of expected unserved energy is calculated using a value of customer reliability (VCR), which is an estimate of the value electricity consumers put on having a reliable electricity supply. AusNet Services and United Energy have applied VCR values based on the Australian Energy Regulator's (AER) Values of Customer Reliability Review² published in December 2019. Applying the AER's sectorial (residential, commercial, industrial and agricultural) VCRs to terminal station level historical energy composition data from 2018-19, a CBTS VCR of \$34.78/kWh was derived, as presented in Table 6.

Table 6 – Value of customer reliability

Sector	AER VCR (\$/kWh)	Sectorial consumption (% of CBTS annual energy)	Energy consumption weighted VCR (\$/kWh)
Residential	\$21.43	47.2%	10.12
Agricultural	\$37.87	2.9%	1.09
Commercial	\$44.52	42.9%	19.11
Industrial	\$63.79	7.0%	4.46
Composite – all sectors			34.78

This CBTS VCR of \$34.78/kWh been applied in valuing the cost of expected unserved energy reported in this project specification consultation report.

3.3.6 Discount rate

It is necessary to apply a discount rate to estimate the present value of future costs and benefits and also for estimating the annual deferred augmentation charge of the proposed preferred option, which may be used as an indicative maximum annual payment that could be available to a non-network service provider for meeting the identified need.

A real, pre-tax discount rate of 3.0% per annum has been applied to the assessments presented in this report. Additionally, an annual operating and maintenance cost of 1% of the project's capital cost has been applied.

² <https://www.aer.gov.au/networks-pipelines/guidelines-schemes-models-reviews/values-of-customer-reliability>

4 Technical characteristics of the identified need

This section outlines the technical characteristics of the identified need that a non-network (network support) option would be required to deliver. It also presents the probability weighted annualised cost of the limitations which, without an identified proposed preferred option, represents the maximum fee that, combined, AusNet Services and United Energy could pay to a network support proponent mitigating the identified need.

Based on the current preferred network option, the optimal investment timing is before summer 2022-23. The annualised deferral cost of the preferred network option (Option 3) is \$1.34 million, which represents the maximum available annual payment that is available to non-network providers from summer 2022-23.

As a minimum, in order to defer the augmentation a network support option would be required to maintain existing loading levels, and hence maintain the expected unserved energy at summer 2021-22 levels. This means that, as a minimum, 8 MVA of non-network support is required for summer 2022-23. It should however be noted that at this level of support for summer 2022-23 the amount a non-network proponent could claim is very little since the expected unserved energy would only be just below the annualised deferral cost.

In order to claim the majority of the annualised deferral cost from summer 2022-23 a network support option will be required to mitigate the system normal level of risk forecast each year under 10% PoE conditions, which is presented as the pre-contingent thermal limitations in the leftmost columns of Table 7. This requirement is forecast to increase from 28.2 MVA for 12 hours in 2022-23 to 81.7 MVA and 29 hours by 2028-29.

In addition to the pre-contingent network support requirements identified, Table 8 presents the post-contingent network support requirements. A non-network option will be considered viable if it can economically manage the identified supply risk by deferring, by one or more years, or eliminating the need for network augmentation.

The maximum demand load curve in Figure 4 shows that the demand at CBTS typically remains high over between 4:00pm and 9:00pm. Any pre-contingent non-network solution will therefore typically need to be capable of operating continuously over this period, until the demand declines. Any post-contingent non-network solution will need to be capable of operating continuously, during high demand periods where there is insufficient spare capacity in neighbouring distribution feeders, until the faulted asset is repaired or replaced, or the demand declines.

Table 7 – Pre-contingent network support requirements

Year	N Thermal Limitations					
	10% PoE Summer		50% PoE Summer		Risk - Probability Weighted	
	Load at Risk / Network Support Requirement (MVA)	Hours at Risk (Hours)	Load at Risk / Network Support Requirement (MVA)	Hours at Risk (Hours)	Expected Unserved Energy (MWh)	Cost of Expected Unserved Energy (\$k)
2020-21	13.2	7	-	-	12.4	432
2021-22	19.8	9	-	-	28.3	986
2022-23	28.2	12	-	-	54.8	1,907
2023-24	35.4	15	-	-	83.3	2,897
2024-25	47.1	20	-	-	142.6	4,959
2025-26	53.1	22	-	-	178.8	6,218
2026-27	61.9	25	-	-	237.8	8,270
2027-28	70.0	27	-	-	296.9	10,323
2028-29	81.7	29	8.0	1	392.0	13,633

Cranbourne Terminal Station Electricity Supply RIT-T

Table 8 – Post-contingent thermal risk and network support requirements

Year	N-1 Thermal Limitation (Post-contingent support)					
	10% PoE Summer		50% PoE Summer		Risk -	Probability
	Load at Risk / Network Support Requirement (MVA)	Hours at Risk (Hours)	Load at Risk / Network Support Requirement (MVA)	Hours at Risk (Hours)	Expected Unserved Energy (MWh)	Cost of Expected Unserved Energy (\$k)
2020-21	118.2	58	53.1	15	7.4	259
2021-22	124.8	62	59.6	19	8.6	298
2022-23	133.2	67	68.0	25	10.2	356
2023-24	140.4	71	75.2	30	11.8	412
2024-25	152.1	79	82.2	34	14.2	493
2025-26	158.1	85	88.6	39	15.9	552
2026-27	166.9	94	95.2	44	18.2	632
2027-28	175.0	101	104.5	52	21.1	735
2028-29	186.7	112	117.0	62	25.8	897

4.1 Data requirements from non-network service providers

Non-network service providers interested in providing submissions to alleviate the network constraints outlined are advised to begin engagement with AusNet Services and United Energy as soon as possible. A detailed proposal including the information listed below should be submitted by the requested date. Details required include:

- Name, address and contact details of the person making the submission.
- Name, address and contact details of the person responsible for non-network support (if different to above).
- A detailed description of services to be provided including:
 - Size (MW/MVA)
 - Location(s)
 - Frequency and duration
 - Type of action or technology proposed
 - Proposed dispatching arrangement
 - Availability and reliability performance details
 - Period of notice required to enable the non-network support
 - Proposed contract period and staging (if applicable)
 - Proposed timing for delivery (including timeline to plan and implement).
- High-level electrical layout of the proposed site (if applicable).
- Evidence and track record proving capability and previous experience in implementing and completion of projects of the same type as the proposal.
- Preliminary assessment of the proposal's impact on the network.
- Breakdown of lifecycle cost to providing the service, including:
 - Capital costs (if applicable)
 - Annual operating (i.e. set up and dispatch fees) and maintenance costs

Cranbourne Terminal Station Electricity Supply RIT-T

- Other costs (e.g. availability, project establishment, etc.).
- A method outlining measurement and quantification of the agreed service, including integration of the proposed solution with the network.
- A statement outlining that the non-network service provider is prepared to enter into a Network Support Agreement (NSA) (subject to agreeing terms and conditions).
- Letters of support from partner organisations.
- Any special conditions to be included in an NSA.

All proposals must satisfy the requirements of any applicable laws, rules and the requirements of any relevant regulatory authority, including following the normal network connection processes where applicable. Any network reinforcement costs required to accommodate the non-network solution will typically be borne by the proponent of the non-network solution.

For further details on AusNet Services' and United Energy's processes for engaging and consulting with non-network service providers, and for investigating, developing, assessing and reporting on non-network options as alternatives to network augmentation, please refer to the Demand Side Engagement Strategy and other relevant demand management documentation at the links below.

- <https://www.ausnetservices.com.au/Residential/Electricity/Demand-Management>
- <https://www.unitedenergy.com.au/wp-content/uploads/2019/07/UE-PL-2202-Demand-Side-Engagement-Document.pdf>

5 Potential credible options to address the identified need

This section lists and briefly describes options that AusNet Services and United Energy consider may be capable of meeting the identified need.

The potentially credible options considered to address the identified need include:

- Option 1 - Do nothing;
- Option 2 – Non-network solution;
- Option 3 - Install fourth 220/66 kV transformer at CBTS;
- Option 4 - Install two 50 MVAR 66 kV capacitor banks;
- Option 5 – Establish two new feeders to offload CBTS;
- Option 6 – Establish a new 220/66 kV terminal station.

5.1 Option 1 – Do nothing

The Do Nothing option, continuing to supply customers serviced by the CBTS without any intervention to manage energy at risk, will lead to significant supply interruptions and expected unserved energy under both N N-1 conditions at peak demand times. In the context of this RIT-T, the Do Nothing option is considered a credible option, and is also used as a comparison case to which all other credible options will be compared to identify the option that maximises the present value of net economic benefit.

As detailed in Table 1 and Table 2, the service level risk associated with the Do Nothing option is forecast to increase from \$690k in 2020-21 to \$14,530k by 2028-29.

Since no step change expenditure is implemented under the Do Nothing option, and the costs and benefits of all other options are measured relative to it, the Do Nothing option is considered a zero-cost option.

5.2 Option 2 – Contract network support services

This option is to contract network support services, local to the CBTS supply area, to meet the identified need. Network support services could include services such as voluntary load reduction, solar PV and battery aggregation and control, large scale battery and/or generator dispatch.

Section 4 details the required technical characteristics as well as the maximum fees available to a non-network service provider based on the current preferred network option. Network support may also be combined with suitable network augmentation options to defer or reduce the scope of a credible network option.

5.3 Option 3 – Install fourth 220/66 kV transformer at CBTS

This option involves installing a fourth 220/66 kV transformer at CBTS to increase the N rating of the station to 700 MVA (40°C rating) and the N-1 rating to 467 MVA (40°C rating). There is already provision for a fourth transformer at CBTS. This option would also involve rearranging the 66 kV feeders to allow the station to operate with the 66 kV bus split so maximum short circuit levels can be maintained within equipment ratings.

The scope of work required for this option includes:

- Supply and installation of a new fourth 150 MVA 220/66 kV transformer to the west of the existing transformers, including firewalls.
- Installation of a new 220 kV circuit breaker.
- Extend the No.1 66 kV bus with two new circuit breakers and establish a new No.4 66 kV bus with five new 66 kV circuit breakers.
- Supply and install a neutral earth reactor at the new fourth transformer 66 kV neutral that matches the neutral earth reactors at all existing transformers.
- A new auto-reclose scheme, which will provide for parallel operation of three transformers in the event of a transformer or bus outage.
- Installation of a wall tubular busbar under the transformer exits.
- Relocation of AusNet Services' and United Energy's 66 kV feeder exits.

Cranbourne Terminal Station Electricity Supply RIT-T

This option meets the identified need by alleviating the supply capacity risk and removing nearly all the expected unserved energy at CBTS, after installation of the fourth transformer at CBTS, over the next ten years. Based on the current assessment, this option maximises the net market benefits and is therefore the preferred network option. The estimated capital cost of this network option is \$26.3 million (direct real \$2020) which, based on the optimal project timing, represents a present value capital cost of \$25.0 million and an annualised cost of \$1.34 million. Based on this annualised cost the optimal timing for the fourth transformer is before summer 2022/23.

5.4 Option 4 – Install two 50 MVAR 66 kV capacitor banks

This option involves installing two 50 MVAR 66 kV capacitor banks to reduce the net MVA supplied by the transformers and defer the need for a fourth transformer at CBTS.

Currently, CBTS operates at a power factor of approximately 0.97 lagging in summer and does not have any 66 kV capacitor banks. Two 50 MVAR 66 kV capacitor banks will reduce approximately 14 MVA from being supplied by the transformers and could defer the proposed preferred network augmentation by one year to summer 2023-24. The estimated capital cost of the capacitor banks is \$3.0 million (direct real \$2020).

Like Option 3 this option meets the identified need by alleviating the supply capacity risk and removing nearly all the expected unserved energy, after installation of the fourth transformer at CBTS, over the next 10 years. The total present value capital cost of this network option, including the deferred installation of the fourth transformer, is \$27.2 million, and has an annualised cost of \$1.50 million.

5.5 Option 5 – Establish two new 22 kV feeders to offload CBTS

This option involves establishing two new 22 kV distribution feeders, from zone substations supplied from two adjacent terminal stations, to offload CBTS and defer the need for a fourth transformer. It includes establishing a new feeder from each of Mordialloc (MC) zone substation and Frankston South (FSH) zone substation, supplied by Heatherton Terminals Station (HTS) and Tyabb Terminal Station (TBTS) respectively, to offload zone-substations CRM and LWN, which are both currently supplied from CBTS.

In total this option requires the establishment of 2.7km of underground cable for the new MC feeder and 2.1km of underground cable for the new FSH feeder. Establishing these two feeders will allow 15 MVA to be offloaded from CBTS and could defer a network augmentation by two years to summer 2024-25. The estimated capital cost of the 22 kV feeders is \$3.4 million (direct real \$2020).

Similar to Option 3, this option meets the identified need by alleviating the supply capacity risk and removing nearly all the expected unserved energy, after installation of the fourth transformer at CBTS, over the next 10 years. The total present value capital cost of this network option, including the deferred installation of the fourth transformer, is \$26.9 million, and has an annualised cost of \$1.52 million.

5.6 Option 6 – Establish a new 220/66kV terminal station

This option involves establishing a new two transformer 220/66 kV terminal station in the Pakenham area, with a site yet to be acquired.

Another site option for a new terminal station would be on a reserved site in North Pearcedale, although this is not located within the growth area and is considered suboptimal at this time.

This option also meets the identified need by alleviating the supply capacity risk and removing nearly all the expected unserved energy over the next 10 years. However, this option is by far the most expensive option with a total estimated capital cost of \$140 million (direct real \$2020) which, based on the optimal project timing of 2026/27, results in a present value capital cost of \$120 million, and has an annualised cost of \$7.25 million.

6 Submissions and next steps

6.1 Request for submissions

AusNet Services and United Energy invites written submissions and enquires on the matters set out in this project specification consultation report (PSCR) from Registered Participants, AEMO, interested parties, non-network providers and those registered on our demand side engagement registers.

All submissions and enquiries should be directed to:

Jason Pollock
Principal Engineer – Strategic Network Planning
Email: Jason.Pollock@AusNetServices.com.au

Christopher Roberts
Senior Network Planning Engineer
Email: Christopher.Roberts@ue.com.au

Submissions are due on or before 25 September 2020.

Submissions will be published on the Australian Energy Market Operator (AEMO's), AusNet Services and United Energy websites. If you do not wish for your submission to be published please clearly stipulate this at the time of lodging your submission.

6.2 Next steps

Following conclusion of the PCSR consultation period, AusNet Services and United Energy will, having regard to any submissions received on the PSCR, prepare and publish a project assessment draft report (PADR) including:

- A summary of, and commentary on, the submissions on the PSCR;
- A detailed market benefit assessment of the proposed credible options to address the identified need; and
- Identification of the proposed preferred option to meet the identified need.

AusNet Services and United Energy intend on publishing the PADR in Q4 2020.